



### Preliminary Specifications: SM31-EZ(-T)

System Type	3 inch full-range, surface-mount, 8 ohm with optional 20-watt transformer for 25/70.7/100-volt applications
Impedance (nominal) <sup>1</sup>	8 ohm
Sensitivity dB @ 2.83 V/1 m	86.0 dB
Sensitivity dB @ 1 W/1 m <sup>2</sup>	86.0 dB
Frequency Response (-3 dB) <sup>3</sup>	150 Hz - 22 kHz
Frequency Response (-10 dB) <sup>3</sup>	100 Hz - 22 kHz
Max. Program Power <sup>4</sup>	40 W
Max. Continuous Power RMS <sup>5</sup>	20 W
Max. Power SPL @ 1 m <sup>6</sup>	101.0 dB
Coverage Angle (-6 dB @ 2 kHz)	N/A
Coverage Angle (-6 dB @ 10 kHz)	N/A
Coverage Angle (averaged from 2 to 10 kHz)	105°
Angle of Pointability	0 to 90° vertical 0 to 359° axial (full hemisphere)
Directivity Factor (Q)	N/A (averaged 100Hz - 10kHz), N/A (2kHz)
Directivity Index (DI) dB	N/A (averaged 100Hz - 10kHz), N/A (2kHz)
Tap Selector	Five-position tap switch (transformer accessory only)
Transducer - Full-Range Driver	76.1 mm (3.0 in.) Polypropylene driver with butyl rubber surround
Enclosure Material	ABS
Grille	Corrosion-resistant, powder-coated aluminum
Inputs	Screw terminal
Colors	Black or white
Height	110.4 mm (4.35 in.)
Width	110.4 mm (4.35 in.)
Depth (including mounting bracket)	96.9 mm (3.81 in.)
Weight	0.6 kg (1.4 lbs.)
Shipping Weight	0.9 kg (2.0 lbs.)
Packaging	One per box
Included Accessories	N/A
Optional Accessories	20-watt transformer (AC-SM31-XFMR), Single gang junction box mounting plate (AC-SM31-MP)
Regulatory - UL	UL 1480 (UEAY) approved (SM31-EZ and transformer)
Regulatory - CE	Approved
RoHS	Approved

<sup>1</sup> Impedance listed per IEC 60268-5 with a minimum less than 80% the nominal impedance  
<sup>2</sup> 1 W 1 m sensitivity determined using nominal impedance  
<sup>3</sup> Frequency response measured in half or full space as dictated by speaker mounting configuration  
<sup>4</sup> Max program power is 3 dB above max continuous power  
<sup>5</sup> Continuous power rating, EIA-426-B test  
<sup>6</sup> Max output based on max continuous power

Transformer Taps		70.7 V	Output	100 V	Output	25 V	Output
20 W	100.0 dB	20 W	100.0 dB	5 W	94.0 dB	5 W	94.0 dB
10 W	97.0 dB	10 W	97.0 dB	2.5 W	91.0 dB	2.5 W	91.0 dB
5 W	94.0 dB	5 W	94.0 dB	1.25 W	88.0 dB	1.25 W	88.0 dB
2.5 W	91.0 dB	2.5 W	91.0 dB	0.63 W	85.0 dB	0.63 W	85.0 dB
1.25 W	88.0 dB	1.25 W	88.0 dB	0.32 W	82.0 dB	0.32 W	82.0 dB

### Key Features

- Two models are available, the SM31-EZ and the SM31-EZ-T. The latter includes a 20-watt transformer.
- One 3 inch (76.1 mm) polypropylene driver with butyl rubber surround
- Weatherized components for indoor/outdoor applications.
- Theft- and corrosion-resistant mounting mechanism with an indexed swivel-joint for precision aiming in any direction.
- Ultra-low profile ZeroReflection™ ABS enclosure (4 inch diameter by 3.5 inch deep, including mounting plate).
- Five position selectable tap switch (SM31-EZ-T only)
- Corrosion-resistant, powder-coated aluminum grille.
- UL 1480 (UEAY) approved.
- High quality black or white paint finish.
- Optional accessories: the SM31-EZ-T includes a 20-watt transformer (AC-31-XFMR) that incorporates a 5 position tap switch and a wall plate for installation in a single-gang deep junction box. This transformer kit is also available as an optional accessory.

### Description

The SM31-EZ(-T) is a premium full-range 3 inch surface-mount speaker, with overall dimensions smaller than a 4 inch sphere. The SM31-EZ(-T) incorporates a proprietary attachment with indexed swivel-joint for complete hemispherical aiming. Components have been weatherized for indoor/outdoor applications.

The SM31-EZ is an 8 ohm speaker without transformer. The SM31-EZ-T is shipped with the AC-SM31-XFMR transformer module to add a 20W transformer and 5 position tap switch that mounts into a single-gang deep junction box.

### Applications

Engineered for rapid installation and low profile mounting for smaller venues, the SM31-EZ(-T) is ideal for retail, restaurants, conference rooms, patio areas, educational facilities or any setting where full-range intelligibility, unobtrusive design and installation ease are paramount. For additional bass response down to 41 Hz (-10 dB), the SM1001p powered 10-inch subwoofer may be incorporated.



## Patented SoundTube Technologies

SoundTube Entertainment and the MSE Audio Group constantly develop new technologies which enhance audio product performance. SoundTube Entertainment innovations are protected by multiple U.S. and international patents, which explicitly cover SoundTube dome, enclosure and dispersion technologies. The MSE Audio Group actively defends its patents in order to protect SoundTube resellers and end-users.

## Technical Data and Specification Tools

### Technical Data

SoundTube Entertainment strives to provide complete and effective technical information and data to dealers, engineers and designers. All data are available from SoundTube Entertainment or at [www.soundtube.com](http://www.soundtube.com).

Technical data and downloads include:

EASE™ data – 3-D polar plots.

EASE™ Address – 2-D modeling for distributed systems

Autodesk® Revit® software

Tech Sheets – Technical information and architectural specs for system engineers

SoundTubeSPEC™ – Proprietary speaker placement software

### Acquisition and Verification

All data for SoundTube speakers are independently collected from and verified by NWAALabs ([www.nwaalabs.com](http://www.nwaalabs.com)) using their proprietary MACH testing system. All data are collected and analyzed according to ASTM, ISO and AES standards using EASERA, TEF and MLSSA. Full balloon data including both phase and magnitude is compiled into a variety of formats including EASE 4.x, GLL and CLF.

## Architectural Specifications

The loudspeaker transducer shall consist of one full-range 76.2 mm (3.0 in.) polypropylene cone with butyl rubber surround.

Performance specifications for a typical production unit shall be as follows: Useable frequency response shall extend from 100 Hz – 22 kHz (-10 dB). Measured sensitivity (2.83 volt input, 1 meter) shall be at least 86.0 dB. The speaker shall have a nominal impedance of 8 ohms, with an optional 20-watt transformer (AC-SM31-XFMR) for distributed systems. The optional transformer shall have a five-position tap switch for 25-, 70.7- and 100-volt applications. Rated power capacity shall be at least 20 watts continuous (RMS) and conform to EIA-426-B. Maximum continuous power output at 1 meter shall be 101 dB.

Surface-mount installation for the unit is designed to mount to wall, ceiling or other rigid structure. When the optional 20-watt transformer is incorporated, mounting shall be to a single-gang deep junction box. Vertical and horizontal pivoting shall be employed to offer unlimited aiming capability for indoor and outdoor applications. Installation for the speaker shall be by proprietary and corrosion-resistant ball mount with an indexed swivel-joint for precision aiming.

External wiring shall be by low-profile screw terminal and shall accept from 10 – 22-gauge wire. The system shall be for indoor/outdoor applications.

The enclosure shall be constructed of injection-molded, ABS. The grille shall be constructed of powder-coated aluminum for lasting performance and affix to the speaker baffle via pressure fit. Overall cabinet dimensions shall be no more than 110.4 mm (4.35 in.) in height by 110.4 mm (4.35 in.) in width by 96.9 mm (3.81 in.) in depth including the mounting bracket.

The system shall be the SM31-EZ for low-impedance applications or the SM31-EZ-T for high-impedance applications.

## SoundTube Entertainment

6430 North Business Park Loop  
Park City, Utah 84098  
Phone 435.647.9555  
Fax 435.647.9666  
Toll Free 800.647.TUBE  
[www.soundtube.com](http://www.soundtube.com)

**All SoundTube products come with a 5-year limited warranty.**

# SM31-EZ(-T) | Surface-Mount Speaker

Preliminary Technical Information for System Engineers



**SOUNDTUBE**  
ENTERTAINMENT

## Polar Plots

———— Horizontal  
- - - - - Vertical

125 Hz

250 Hz

500 Hz

1,000 Hz

2,000 Hz

4,000 Hz

8,000 Hz

10,000 Hz

Technical data, EASE™ plots, SoundTubeSPEC™ software and product downloads available at [www.soundtube.com](http://www.soundtube.com)

## Mechanical Drawings

SM31-EZ

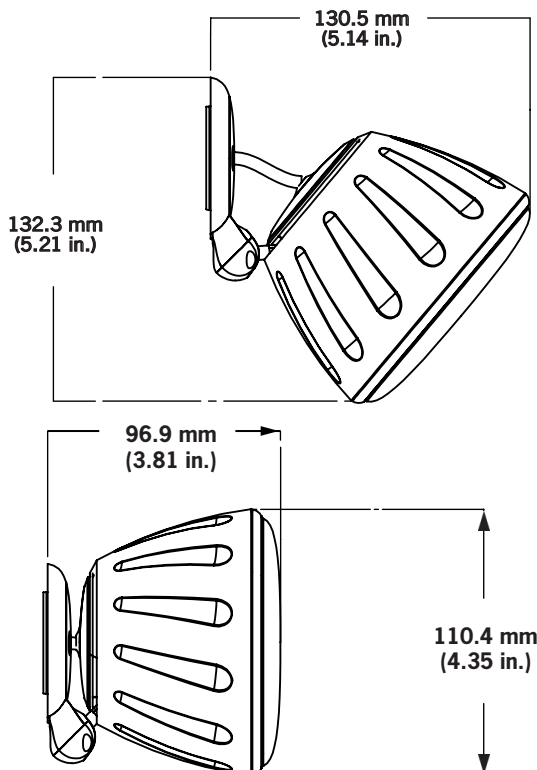

SM31-EZ-T

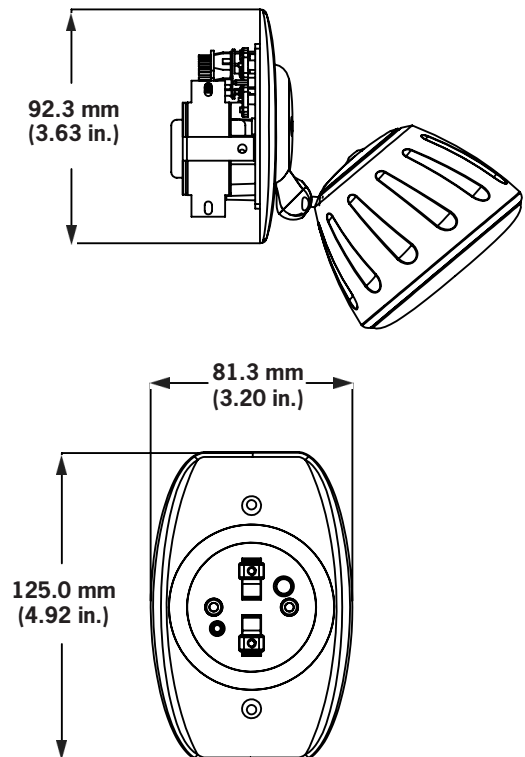

SoundTube Entertainment manufactures a complete line of speakers for:  
**Open-Ceiling • In-Ceiling • Surface-Mount • Outdoor • Sound-Focusing**

All SoundTube products are distributed by SIGNAL INNOVA (800) 417-9060 in the USA.

[www.ExhibitsAlive.com](http://www.ExhibitsAlive.com)